

## HONORS FIZZIX: EXAM #3 2015 SA Section Chapters 2-5

Directions: Show all work & make reasoning clear. You must do #1. Then choose two, and ONLY two, of the remaining 4 AP-Style problems to turn in for grading.

DUE: All *paper and electronic* solutions are due no later than 12:45 PM ET Friday 11/06/2015.

1. (**MUST DO THIS ONE**. 10 pts) Two blocks of non-magnetic Titanium, element #22, each with mass  $M$ , are attached to the opposite ends of a massless frictionless rope. The rope has a length of  $6X$ , where  $5X$  of the rope is horizontal on the table and  $3X$  is the height of the frictionless table. One of the blocks, Block **A**, is sitting on the table while the other block, Block **B**, is suspended over the side of the table, as shown below. At time  $t = 0$ , Block **B** is held at rest at a height of  $2X$  above the floor at time  $t = 0$ . Answer all the following questions in terms of  $X$ ,  $M$ , and  $g$ .

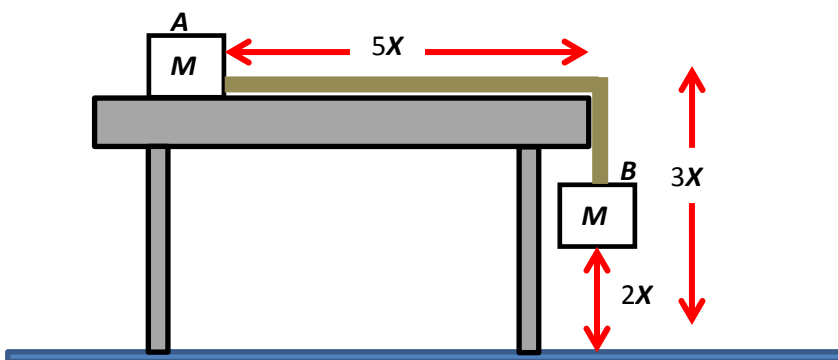

(A) What is the acceleration of Block **B** when released from rest?

(B) After a certain time, Block **B** hits the floor without bouncing, but makes a loud sound that bothers the teachers on the 1<sup>st</sup> Floor. Find the time it took Block **B** to hit the floor.

(C) Describe *in detail* the motion of Block **A** from time  $t = 0$  to the time it gets to the left side of the tabletop.

(D) Find the distance Block **A** lands horizontally away from the tabletop edge.

2. (10 pts) A dumb waiter, not unlike the one I had last night at *Buffalo Wild Wings*, is a simple pulley system where the “carrier” is like an elevator car and over the other side of the pulley hangs a large mass to help lift the carrier; this other mass is called the counterweight. See diagram below for a rough sketch.

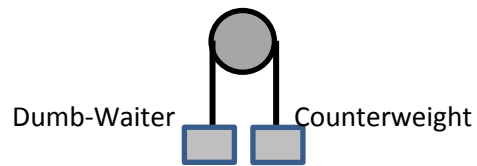

(A) If the dumb-waiter has a mass of 10-kg and is loaded with 4-kg of food, what is the acceleration of the dumb-waiter if the counterweight on the other side of the frictionless pulley has a mass of 18-kg?

(B) What mass counterweight would have to be used to give the same loaded dumb-waiter an acceleration of  $2 \text{ m/s}^2$  upward?

(C) What is the tension in the cable holding the loaded dumb-waiter described in part (B) above?

3. (10 pts) Note the diagram below. It is a combination of two examples we did in class. Calculate the minimum coefficient of kinetic friction that keeps the mass moving up the ramp at a constant speed of 5 m/s.

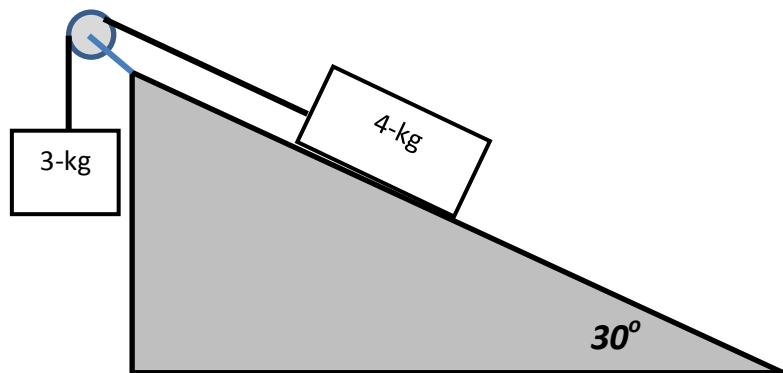

4. (10 pts) This one will make you mad. We've done a batch of problems where a force acts on a block on a ramp, but the applied force was always parallel to the ramp. Not this evil one. In the diagram, a guy who is totally color-coordinated, is pushing a piano of mass  $M$  up a ramp. He applies a force  $F$  horizontally to the piano on a non-smooth ramp that makes an angle of  $\theta$  to the horizontal. That's all you're given.

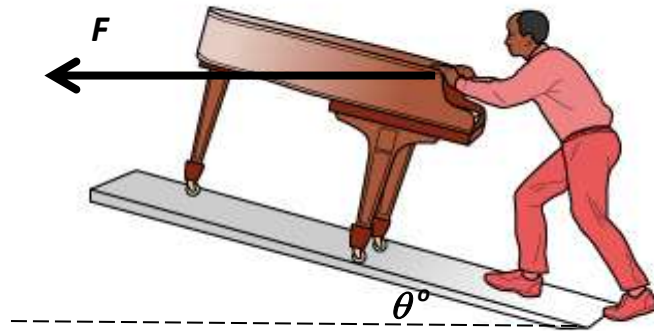

(A) On the piano below, draw a free-body diagram.



(B) Derive an equation for the acceleration of the block in terms of  $g$ ,  $F$ ,  $\theta$ ,  $m$ , &  $\mu$ .

(C) Derive an equation for the magnitude of the force necessary to keep the block moving up the ramp at a constant speed.

5. (10 pts) A huge box of unused Fizzix textbooks of mass  $M$  is pulled along a not-smooth horizontal floor by means of a constant force,  $F$ , acting at an angle of  $\theta$  above the horizontal as shown below. The coefficient of kinetic friction between the box and floor is  $\mu$ . Express all your answers in terms of the given variables ( $F$ ,  $M$ ,  $\mu$ ,  $\theta$ , &  $a$ ) and fundamental constants.

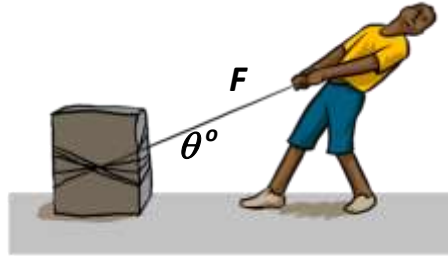

(A) On the diagram below, draw and label all the forces acting on the block. DO NOT break any forces into components.



(B) Derive an equation for the normal force the surface provides.

(C) Derive an equation for the coefficient of friction  $\mu$  between the surface and block.

(D) Determine an expression for the magnitude of a larger force  $F_2$  that would cause the block to lose contact with the surface.